

WASH BASIN

Floor-standing foot-operated hand washbasin



SNLMP60CS
Satin finish

General description

- Floor-standing foot-operated hand washbasin without overflow made of bacteriostatic AISI 304 stainless steel 0.8 mm thick, satin finish.
- It can be wall-mounted and/or floor standing.
- Robust and vandal-proof design, highly resistant to oxidation and very easy to clean thanks to its wide radii.
- Suitable for public use with high resistance and durability. Highly recommended for food companies and for the health sector (hospitals, primary care centers, clinics, etc.).
- Mains water fed foot operated on/off valve to give a true hands free operation.
- Supplied with swan neck spout and time flow tap with 7 second time flow.
- Easy to maintain access panel at the front.
- Supplied with 1¼" waste.
- Supplied with fixing elements for brick walls.
- CE marked. **Complies with European standard EN 14688.**

Components and materials

- **BODY:** made of AISI 304 stainless steel, 0.8 mm thick and satin finished. With access panel at the front to carry out connections to the water mains.
- **BOWL:** made of AISI 304 stainless steel, 0.8 mm thick, directly embedded in the body of the sink.
- **TAP:** adjustable swan neck chrome finish.
- **PUSH BUTTON:** stainless steel timer that avoids all manual contact of the user with the sink.

Technical specifications

Dimensions	385x385x850 mm
Stainless Steel thickness	0,8 mm
Water outlet	1 ¼"
Net weight	10 Kg

Dimensions

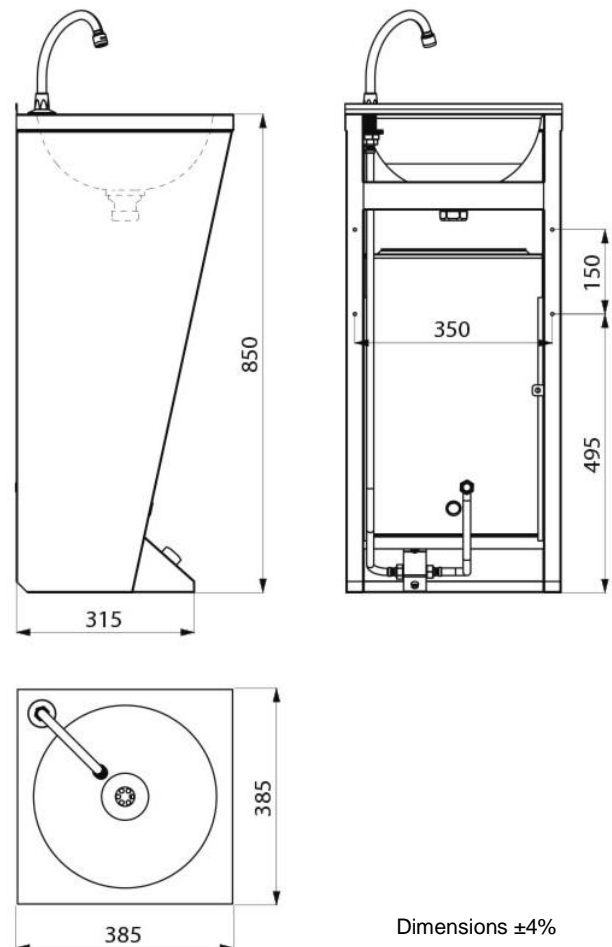

Dimensions ±4%

MOUNTING

Fix the fountain to the wall through the holes marked with an "S" in the following figure:



To assemble the fountain, follow the steps indicated in next figure:

